

DRAWN BY: BILL BERENS

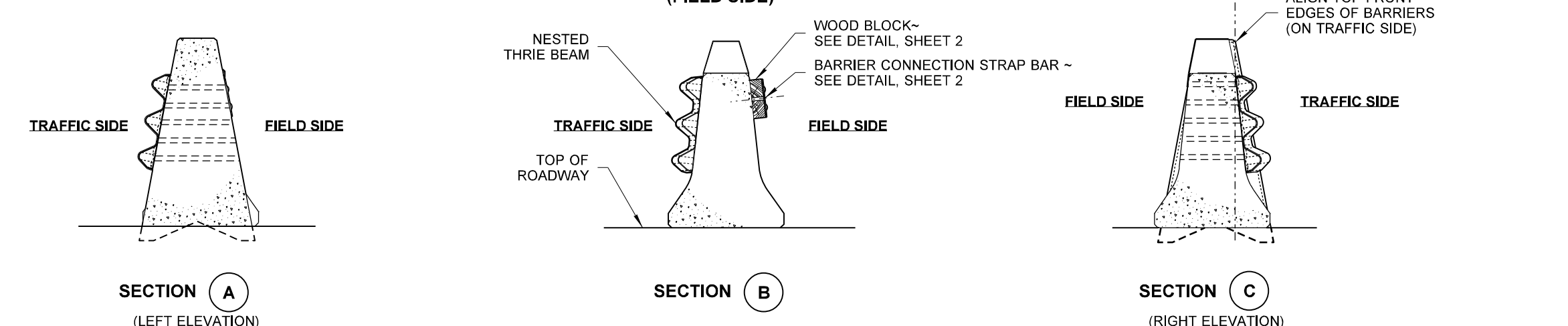

NOTES

- The intent of this plan is to provide a transition from the anchored Type F concrete barrier system to various types of concrete barrier systems (e.g. Single Slope) up to 42" (in) tall. This transition plan applies to roadside or wide median applications where the barrier transition can be impacted on the Traffic Side Only. This transition can be installed on cement concrete pavement or hot mix asphalt pavement.
- Transition Installation Procedure:**
 - Procure a segment of Type F Concrete Barrier (**Standard Plan C-60.10**).
 - Cut the end loops off of the Loop Bars of the Type F section located closest to the dissimilar shaped concrete barrier section.
 - Abut the two sections and align the top front edges (traffic side) of the barrier sections. (See Section C, this sheet).
 - Install the nested thrie beam rail on the traffic side, the barrier connection strap bar on the field side, and the transition shroud to secure the two barrier sections together.
 - Install the anchor pins.
- Refer to **Standard Plan C-60.10 Concrete Barrier Type F** for additional details not shown on this plan.
- Refer to **Standard Plan C-1a Beam Guardrail (Thrie Beam)** and **C-7a Thrie Beam End Sections** for additional details not shown on this plan.
- Install rectangular guardrail plate washers under the bolt head on upstream end and under the nut on the downstream end. See sheet 2 for details.
- Lap thrie beam and thrie beam end section in direction of adjacent traffic. The upstream thrie beam end section is installed on top of thrie beam rail, and the downstream thrie beam end section is installed under thrie beam rail.
- Embed anchor bolt 5" (in) into barrier and secure to barrier with Type I epoxy. Core drill 1 1/2" (in) diameter holes into top of barriers.
- For barrier transition pinning details, See **Standard Plan C-60.70**.

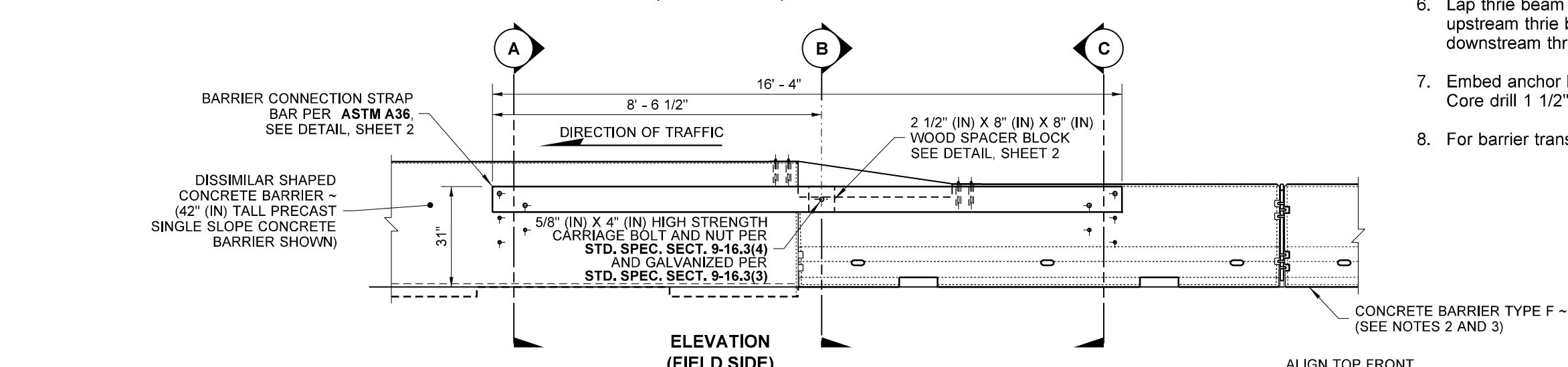
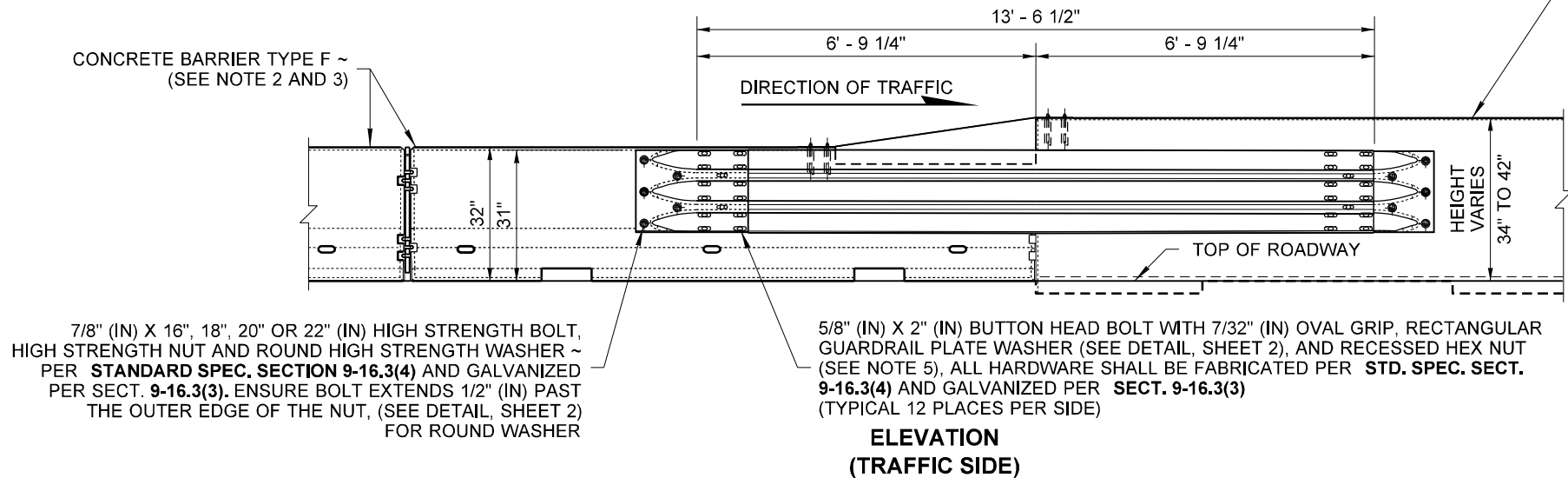
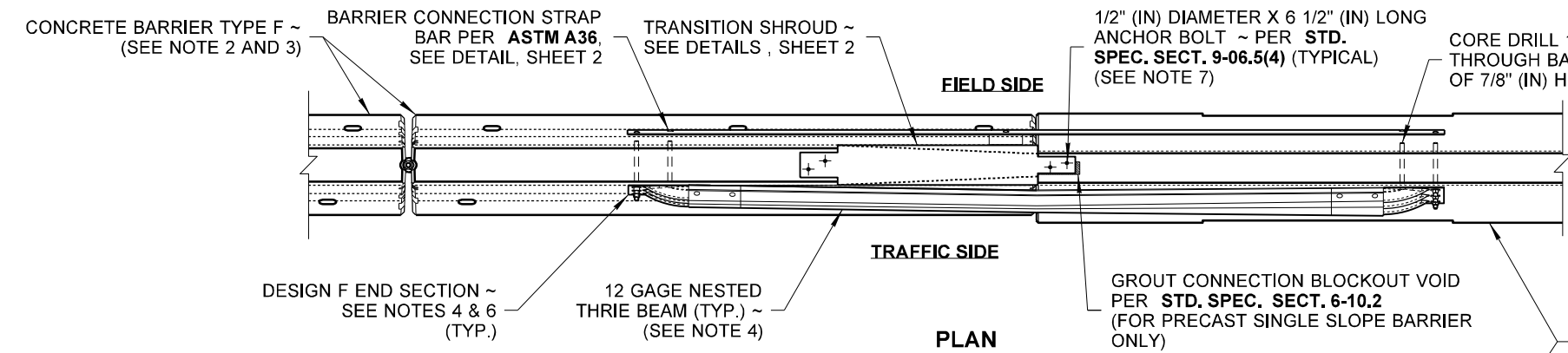

Sep 8, 2022

PRECAST TYPE F BARRIER TO DISSIMILAR SHAPED BARRIER TRANSITION

STANDARD PLAN C-60.20-01

SHEET 1 OF 2 SHEETS

APPROVED FOR PUBLICATION
Mark Gaines
 Mark Gaines (Sep 8, 2022 09:55 PDT) Sep 8, 2022
 STATE DESIGN ENGINEER
 Washington State Department of Transportation

DRAWN BY: BILL BERENS

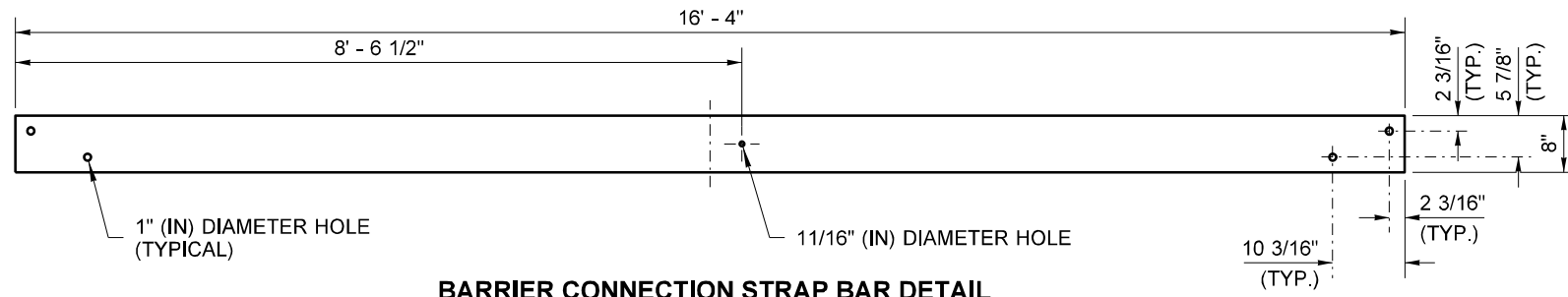

BARRIER CONNECTION STRAP BAR DETAIL
 1/4" (IN) THICK STEEL PER **ASTM A36**
 HOT DIP GALVANIZE, AFTER FABRICATION
 PER **AASHTO M 111** OR **ASTM F2329**

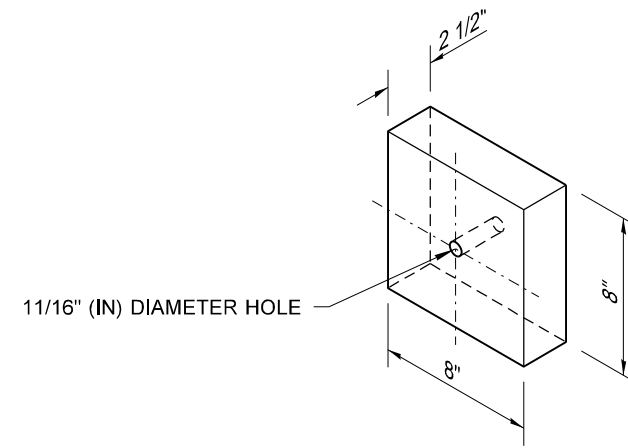

WOOD SPACER BLOCK DETAIL
 WOOD BLOCK SHALL CONFORM TO **STD. SPEC. SECTION 9-09.2(2)**,
 AND BE PRESSURE TREATED PER **STD. SPEC. SECTION 9-09.3(1)**

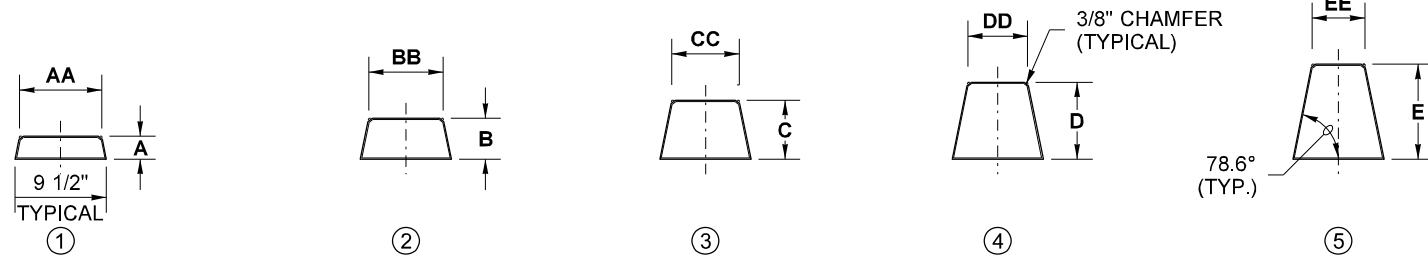

RIB DETAILING
 (10" HEIGHT (H) SHROUD SHOWN)

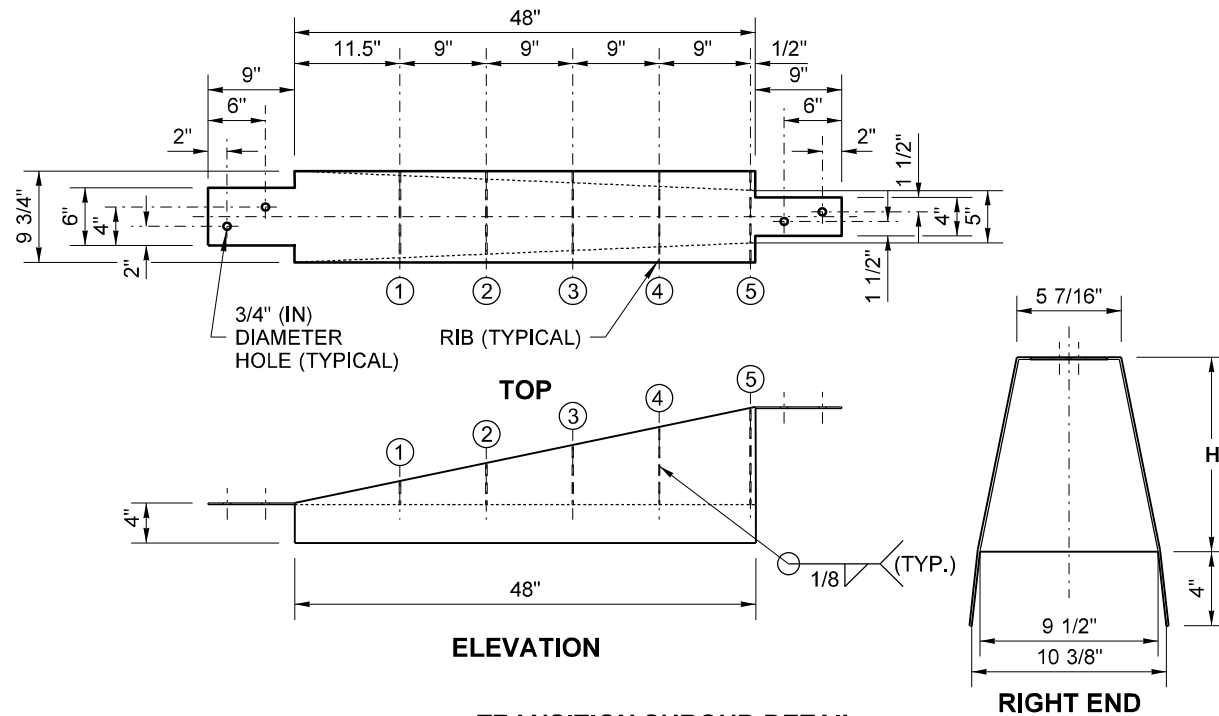

TRANSITION SHROUD DETAIL
 (10" (IN) TALL TRANSITION SHROUD SHOWN)
 1/8" (IN) THICK STEEL PER **ASTM A36**
 HOT DIP GALVANIZE, AFTER FABRICATION PER **ASTM F2329**

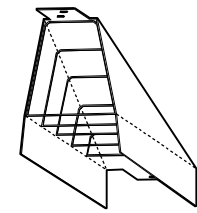

OBLIQUE VIEW

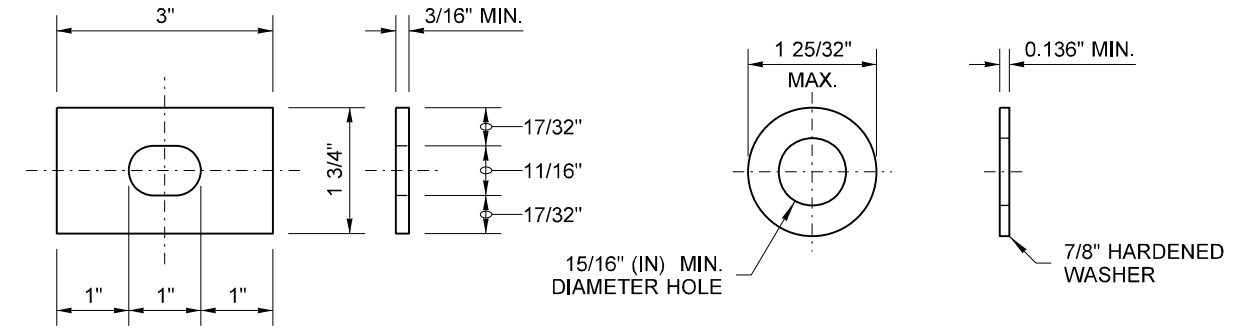

**RECTANGULAR GUARDRAIL
 PLATE WASHER DETAIL**
 SEE NOTE 5
 RECTANGULAR PLATE WASHER SHALL BE
 HIGH STRENGTH AND CONFORM TO
STD. SPEC. SECTION 9-16.3(4) AND
 BE GALVANIZED PER **STD. SPEC. SECT. 9-16.3(3)**

ROUND WASHER DETAIL
 ROUND WASHER SHALL BE
 HIGH STRENGTH AND CONFORM TO
STD. SPEC. SECTION 9-16.3(4) AND
 GALVANIZED PER **STD. SPEC. SECT. 9-16.3(3)**



Sep 8, 2022

**PRECAST TYPE F BARRIER
 TO DISSIMILAR SHAPED
 BARRIER TRANSITION**

STANDARD PLAN C-60.20-01

SHEET 2 OF 2 SHEETS

APPROVED FOR PUBLICATION

Mark Gaines
 Mark Gaines (Sep 8, 2022 09:55 PDT) Sep 8, 2022

STATE DESIGN ENGINEER



TRANSITION SHROUD TABLE

(H)	DIMENSION										NOTES
	A	AA	B	BB	C	CC	D	DD	E	EE	
2"	1/2"	7 13/16"	7/8"	7"	1 1/4"	6 1/4"	1 5/8"	5 1/2"	1 7/8"	4 3/4"	THE TOP AND SIDES OF THE SHROUD MAY BE FABRICATED FROM SEPARATE PLATES AND WELDED TOGETHER AT THE JOINTS, OR MADE FROM A SINGLE PLATE/SHEET AND BENT (BEND RADII - 1/4" (IN) MAX.) OR MADE WITH A COMBINATION OF BOTH METHODS.
4"	1"	7 13/16"	1 3/4"	7"	2 1/2"	6 1/4"	3 1/4"	5 1/2"	3 7/8"	4 3/4"	
6"	1 3/8"	7 13/16"	2 1/2"	7"	3 5/8"	6 1/4"	4 3/4"	5 1/2"	5 7/8"	4 3/4"	
8"	1 7/8"	7 13/16"	3 3/8"	7"	4 7/8"	6 1/4"	6 3/8"	5 1/2"	7 7/8"	4 3/4"	
10"	2 3/8"	7 13/16"	4 1/4"	7"	6 1/8"	6 1/4"	8"	5 1/2"	9 7/8"	4 3/4"	

TRANSITION SHROUD NOTES:

- ① Prior to transition shroud fabrication, verify the height of the dissimilar shaped barrier that the 32" (in) Tall F-shape transition is abutting to. Shroud height: (H) ranges from 1" (in) to 10" (in) tall.
- ② For dimensioning not shown in the table, interpolate dimensions.
- ③ No transition shroud is necessary if the dissimilar shaped barrier is the same height, or up to 1" (in) taller than the 32" (in) Type F barrier.
- ④ Barriers that Type F barrier may transition to include but are not limited to:
A.) Concrete Barrier Type 2 ~ See **Standard Plan K-80.32** for details
B.) Single-Slope Concrete Barrier (Precast) ~ See **Standard Plan C-70.10** for details
C.) Single-Slope Concrete Barrier (CIP) ~ See **Standard Plan C-80.10** for details
D.) High Performance (HP) Single-Sloped Concrete Bridge Barrier ~ See Bridge Standard Drawings
E.) High Performance (HP) F-Shape Bridge Barrier ~ See Bridge Standard Drawings